



MECCANOPLASTICA
GROUP

COMPANY WITH
QUALITY SYSTEM
CERTIFIED BY DNV GL
= ISO 9001:2015 =

TWO STATION BLOW MOULDING MACHINE FOR HOLLOW BODIES

MP5D MP5X

MACCHINA A DUE STAZIONI PER SOFFIAGGIO CORPI CAVI
SOUFFLEUSE A DEUX POSTES POUR CORPS CREUX
MAQUINA DE DOS ESTACIONES DE SOPLADO PARA CUERPOS HUECOS



Scan me

TECHNICAL FEATURES | CARATTERISTICHE TECNICHE | CARACTERISTIQUES TECHNIQUES | CARACTERÍSTICAS TÉCNICAS

Max container volume Volume massimo del contenitore Volume max du récipient Capacidad envase a soplar	L	5
Mould clamping force Potenza di chiusura Puissance de fermeture Potencia de cierre	kN	95
Hydraulic working pressure Pressione idraulica di esercizio Pression pneumatique Presión hidráulica	bar	150
Pneumatic working pressure Pressione pneumatica di esercizio Pression pneumatique Presión neumática de trabajo	bar	6 - 8
Cycle time Tempo per un ciclo Temps d'un cycle Ciclo en vacío cada carro	sec.	2,2
Heating zones Zone di riscaldamento Zones de chauffage Zonas calefacción	n°	min 8

EXTRUDER | ESTRUSORE | EXTRUDEUSE | EXTRUSORAS

Screw diameter Diametro della vite Diametre vis Diámetro del husillo	mm	70	90
Working length Lunghezza utile Longueur utile Relación L/D	mm	24D	
Continuous screw speed Velocità della vite a regolazione continua Vitesse de la vis à réglage continu Velocidad husillo	RPM	0 - 90	0 - 90
Variable speed electric motor Motore elettrico a velocità variabile Moteur électrique à vitesse variable Potencia motor eléctrico	kW	30 (37)	45 (55)
Zones Zone Zones Zonas	n°	5	
Fan cooled zones Zone raffreddate con ventilatori Zones refroidies par ventilateurs Zonas de termostatación con ventiladores	n°	4	
Installed heating power Potenza di riscaldamento installata Puissance de chauffage installée Potencia de calefacción	kW	14	25

POWER CONSUMPTION | CONSUMO ENERGIA | CONSOMMATION ENERGIE | SERVICIOS

Total installed power Potenza totale installata Puissance totale installée Potencia total instalada	kW	59 (66)	85 (95)
Air consumption (6 - 8 bar) Consumo aria (6 - 8 bar) Consommation air (6 - 8 bar) Consumo aire (6 - 8 bar)	NI/min	1.100	

DIMENSIONS | DIMENSIONI | DIMENSIONS | DIMENSIONES

Machine net weight Peso netto impianto Poids net installation Peso neto maquina	Kg	9.500	9.700
---	----	-------	-------

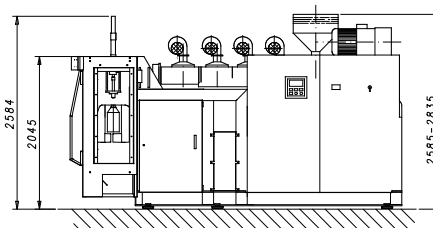
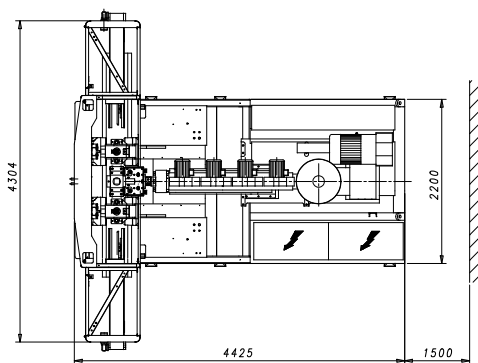

PRODUCTION CAPACITY | POSSIBILITA' DI PRODUZIONE | POSSIBILITES DE PRODUCTION | POSIBILIDAD DE PRODUCCION

x n°	x n°	A mm	L mm	D mm	-	L mm	D mm	B mm	L mm	D mm	
x 1	x 1	-	350	170	-	350	200	170	350	200	170
x 2	x 2	140 - 150 - 160 - 170 - 180	320 320	130 min 170 max	-	320 320	130 min 170 max	100 min 140 max	320 320	120 min 160 max	100 min 140 max
x 3	x 3	100 - 120	320 320	90 min 110 max	-	320 320	90 min 110 max	70 min 90 max	-	-	-
x 4	x 4	85 - 90 100 ^(*)	260 260	75 min 90 ^(*) max	-	260 260	75 min 90 ^(*) max	60 min 70 ^(*) max	-	-	-
x 5	x 5	60 - 70 - 75	200 200	50 min 65 max	-	200 200	50 min 65 max	35 min 50 max	-	-	-
x 6	x 6	60 65 ^(*) - 70 ^(*)	200 200	50 min 60 ^(*) max	-	200 200	50 min 60 ^(*) max	35 min 50 ^(*) max	-	-	-

(*) soltanto per MP5X | only for MP5X | seulement pour MP5X | nur für MP5X

MECCANOPLASTICA srl - via Albert Einstein, 35/51 - 50013 Campi Bisenzio (Firenze) - Italy
 Tel. +39 055.898187 - info@meccanoplastica-group.com - www.meccanoplastica-group.com

